

## Making a Triangle Twist Foundation in EQ5

This lesson is a result of a challenge on the Info-EQ mailing list to create a foundation to use to make [Bonnie Browning's Twisted Log Cabin quilt](#) as seen on HGTV's Simply Quilts, Episode #802. We found a way to use Variable Point layout for creating the quilt in EQ5 to use for color mapping, but we needed an alternative for an accurate foundation -- so that we won't have to draw each foundation over forty times by hand!

The dilemma was the 3/4" measurement Bonnie used for each tilt each new triangle. Since we can't move our ruler on the computer screen, we have to think of an alternative. So...the best we can do is to make our own moveable 3/4" guideline.

**This foundation pattern is our goal:**

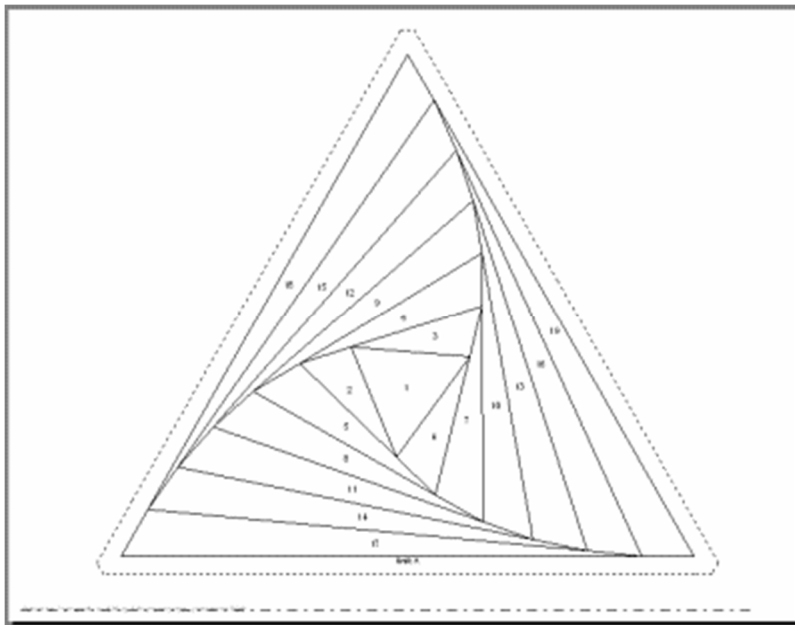

1. Place a new EasyDraw block on the Worktable.
2. In Drawing Board Setup:
  - Snap to Grid: 32 x 32
  - Block Size: 8.00" x 6.93" (*Note: The vertical size is indeed an odd one, but you CAN type it in the Vertical size box without any problem. If you round up to 7" you won't have an equilateral triangle anymore.*)
  - Graph Paper: 8 x 7 (optional)
3. Draw two diagonal lines from the center top (at 4.00") to the left and right corners

to create a 60 degree triangle.

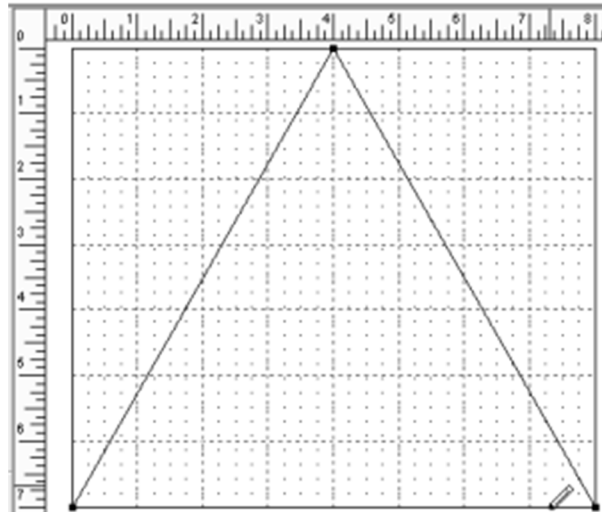

4. Draw a 3/4" line to use as a guide for locating nodes.

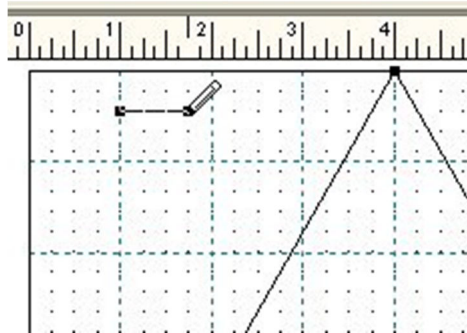

5. With the Select tool, click on the 3/4" line, right-click, choose Rotate from the menu and then rotate it 60 degrees. Once it is rotated, move it over next to the matching angled triangle line, aligning it by eye.

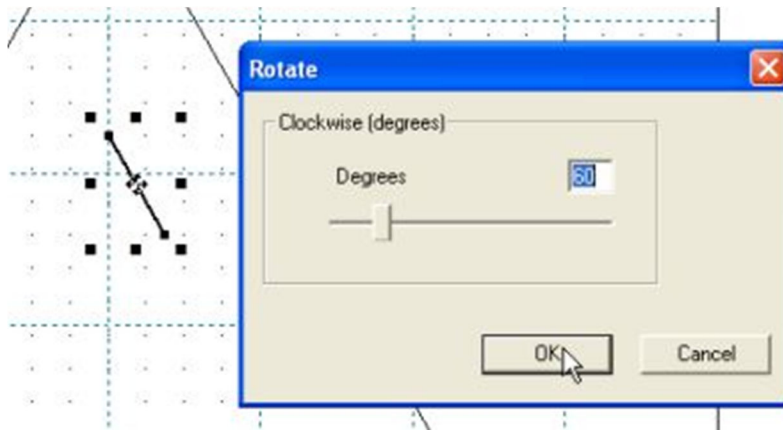

6. Click on the Edit tool, clicking on the small black square to bring up the Edit Line box.

7. Click on the line that makes the right side of the triangle to select it. On the Edit Line box, click on **Locate**. The cursor will change to a crosshair. Using the 3/4" as your guide for placement, point the crosshair over the selected line and click once to add a node. If you don't like the placement use Undo (CTRL+Z) and try again. Repeat this node location on the lower left side of the triangle.

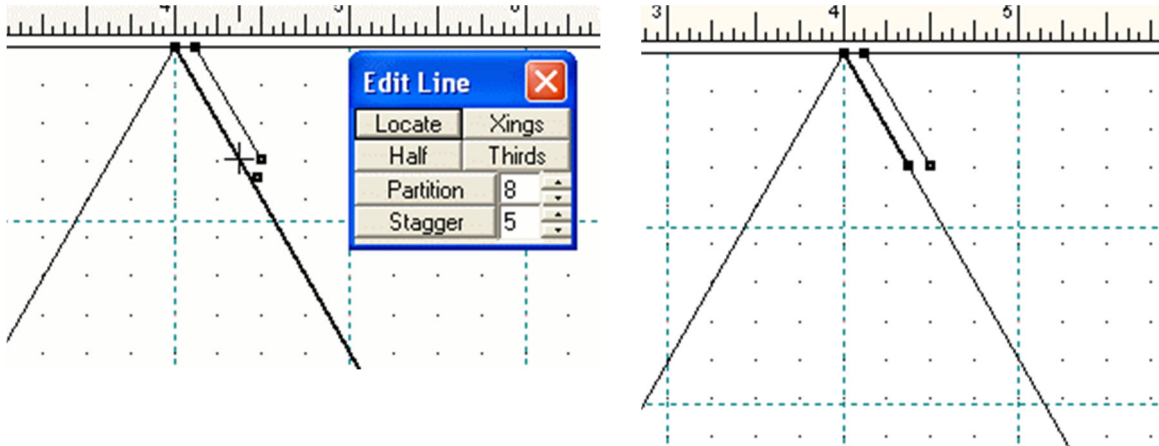

8. Click on the Line tool. Draw lines from node to node to form the tilted triangle. On this first triangle, park the bottom right corner at 7 1/4" (three grid dots from the right). In successive triangles, you will need to use the 3/4" guide and Locate on all three sides of the triangles to create your nodes.

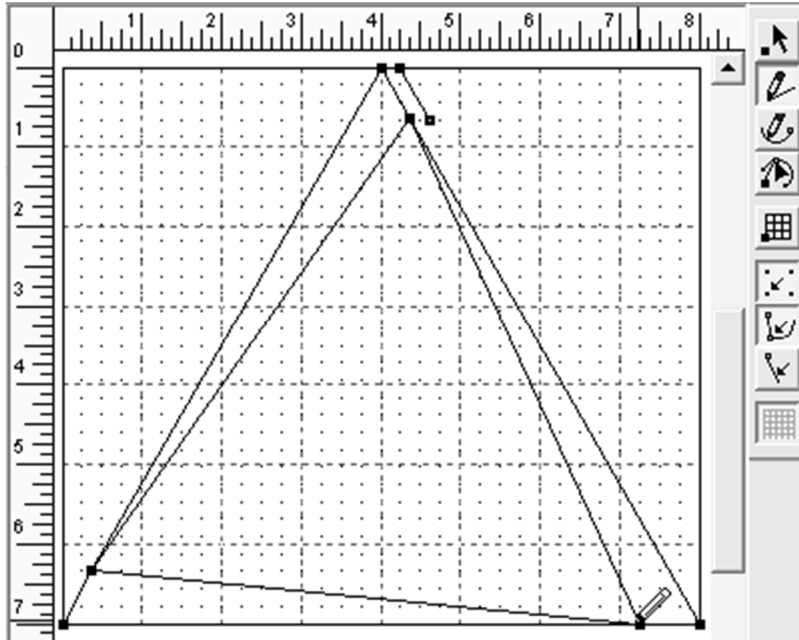

9. Using your 3/4" guide, repeat the procedure to locate nodes in the new tilted triangle to be able to draw the next one. Continue this for each successive triangle. There are a total of 6 tilted triangles in Bonnie Browning's block.

- Once you draw the first tilted triangle, you will find it very helpful to turn OFF the Snap to Grid, leaving only Snap to Node on. It will make moving the 3/4" guide around much easier and will ensure that your lines are snapping to the nodes and not snapping to the grid points. **Turning on and off Snap to Grid is an Advanced Drawing Feature, so please read pages 102 -105 of the EQ5 Design Cookbook if you are not familiar with them and what they do.**
- You may want to save each step as you draw this pattern. HOWEVER, when you save the block, the 3/4" line will disappear since it is not attached to anything. Just redraw it, rotate, and continue.
- **Special Note:** For each separate tilted triangle, you can rotate the 3/4" guide line 60 degrees. As the angle of each tilted triangle changes, you will need to \*free rotate\* your 3/4" guide accordingly. With the Select tool, click on the 3/4" line to select it, then hold down the CTRL key and click on the center of the selected line. When you do this you will see the corner handles change to curves arrows and you will be in rotate mode. Point to one of the corner arrows and rotate the line as needed to make it parallel to the angled line. You will have to eyeball this angle, zoom in if necessary. Click off the selected line to get out of rotate mode.

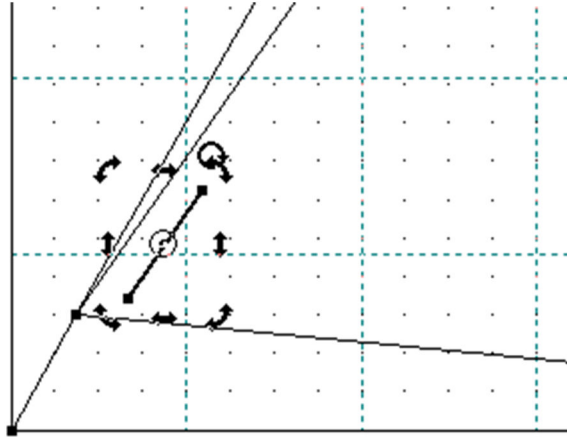

10. Tada! One beautiful twisted triangle...but there's more...

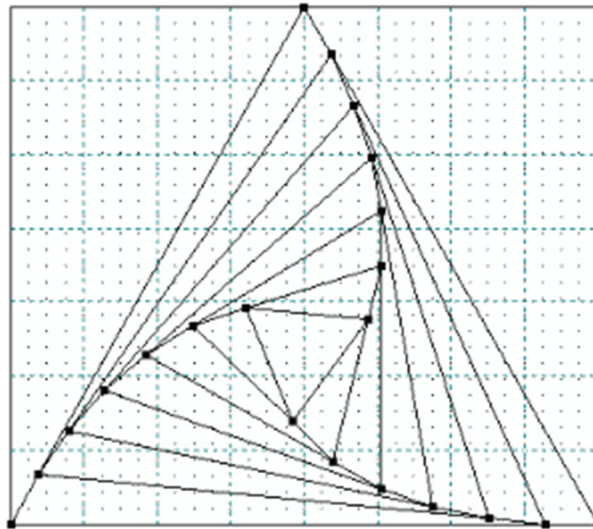

When you go to print this block as a Foundation pattern the two background pieces will be included in the foundation. To eliminate that problem, (make sure Snap to Grid enabled again), draw a line from the sides of the block to a grid point just inside the sides of the triangle. When you save the block, EQ will crop off the excess line. Dividing the background this way will make EQ see them as separate units.

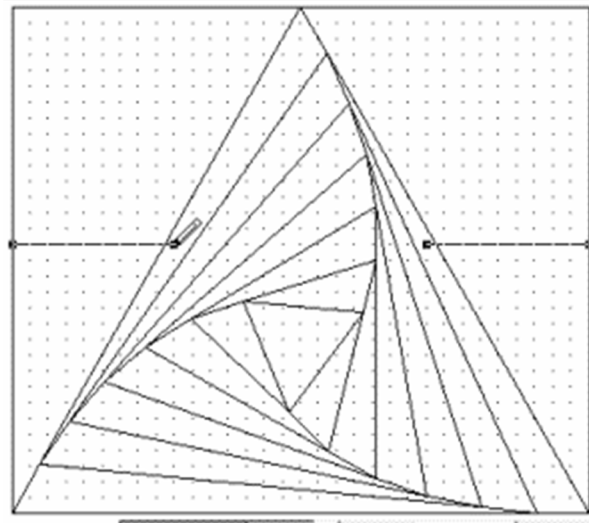

**Print the block with this size: 8.00" x 6.93"**

When you print the foundation, delete these two sections, and then move the foundation up so that it is all on one page. I found the foundation fits best if I use Landscape orientation and decrease the margins to 0.25". Now you can print out the number of triangle foundations needed for your particular quilt. Beats drawing them all by hand, yes?!!

---

### **Here's a couple of bonus hints...**

Print out a color map for piecing this quilt. Even if the quilt you [created in Variable Point layout](#) is not accurate for your foundation, it will work very well for a color map. I just used solid colors to indicate my color placement. Now, get your colored pencils and mark each foundation as needed! Follow [Bonnie's instructions on HGTV's website](#) for cutting the shaded strips and for sewing the foundations.

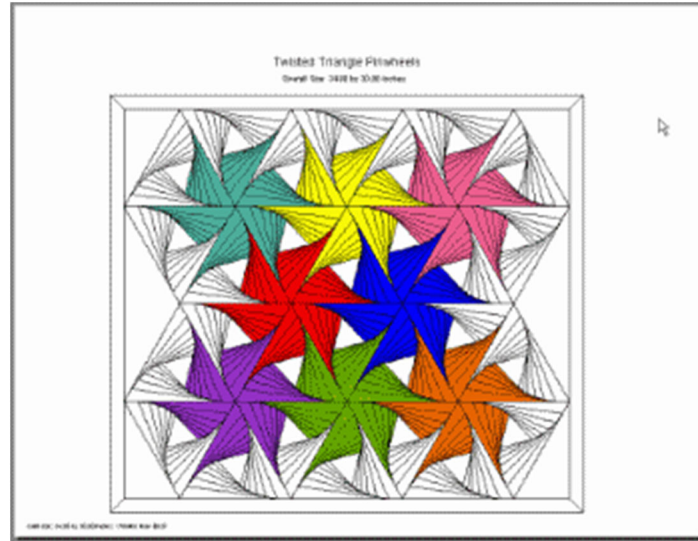

**Yes you can** -- if you have the time, determination, and are a little bit crazy -- take the block one step further (actually more like 6+ steps...) to create the block below to use in Custom Set so that you can play with your own colorings. Divide the block in half by drawing a line down the center. Use the Symmetry box to clone each half and to rotate 180 degrees. *Be sure Snap to Grid is turned back on* when placing the new halves into their respective corners and make certain that they *are* snapping into place. Clean up excess lines **BEFORE** you save the block. Use this block in Custom Set to get the layout for a quilt similar to [Bonnie Browning's quilt](#) on Simply Quilts... or better yet create your own!

